

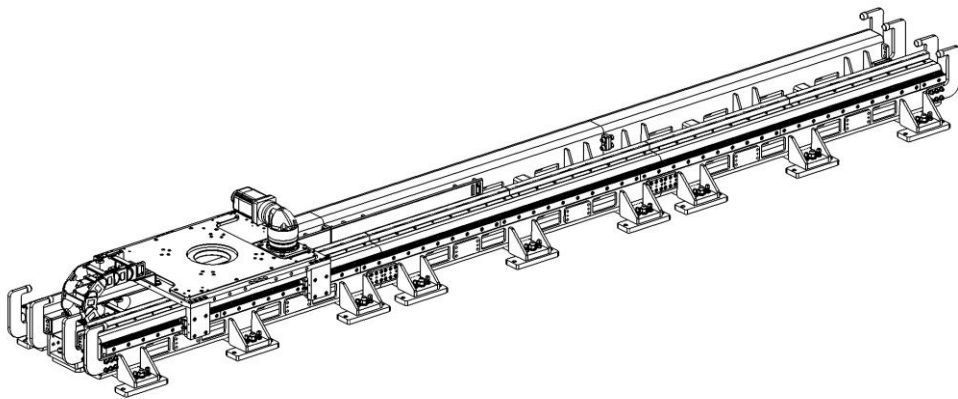

TRK1000

LINEAR TRACK WITH RATED CAPACITY OF 2000 KG



Contents:

1. Introductions	2
2. Technical Parameters	3
3. External dimensions	4
4. Basic assemblies of the basic module	5
4.1. Mechanical system.....	5
4.2. Electrical system	5
5. Assembly and start-up	6
5.1. Assembly	6
5.2. Getting ready for operation	7
5.3. Emergency Stop connection	7
5.3.1. Cubic-S Option	7
5.4. Start-up	7
5.5. Working conditions and safe use	8
5.6. Maintenance of the linear track.....	9
5.7. Maintenance schedule	9
6. Lay of user cables inside the structure	10
7. Storage and transport conditions	10
7.1. Storage	10
7.2. Transport	10
8. Safety information and residual risk	11
8.1. Danger due to mechanical construction:	11
8.1.1. Crushing and cut-offs	11
8.2. Dangers due to the electrical system	11
8.3. Informations about noise emission	11
9. Notes.....	12
10. Manufacturer's data.....	14

Appendix 1 - Spare parts list

1. Introductions

Linear Track TRK1000 is electrically driven unit. It is equipped with one rotary axis controlled in a continuous manner. It is designed to work in a robotic welding station and is used to move the robot or other equipment. It is controlled from the KAWASAKI robot controller as additional axes.

-
- I. These instructions do not constitute a guarantee of the system in which the linear track is installed. Accordingly, the Astor company is not liable for any accidents, damages and/or problems related to industrial property rights arising as a result of using the system.
 - II. It is recommended that all personnel assigned to operating, teaching, servicing or maintaining the linear track attend the necessary courses when installing the system before commencing the performance of their duties.
 - III. The Astor company reserves the right to alter, correct or update this manual without prior notice.
 - IV. Keep the following instructions with care and in a place where they can always be available for use. If the linear track is re-installed or relocated, please attach these complete and unaltered instructions. In case the instructions are lost or damaged, please contact the Astor company
-

2. Technical Parameters

Parameter	TRK1000
Nominal Payload	2000 kg
Maximum payload*	3000 kg
Nominal Speed with 1200kg	1.2 m/s
Max. Speed with 3000kg	0.8 m/s
Max. Capacity of the Robot	300 kg
Min. Travel distance	1000 mm
Maks. Travel distance**	30 000 mm
Min. Travel distance gradation	2000 mm
Repeatability	±0.05 mm
Carriage Mass	310 kg
Carriage mass with options	1000 kg
Default Height of Robot Assembly***	422 mm
Installation Position	Floor
Environment cond.	5-40°C

* with option for Heavy Robots – CP-series

** restricted by harness lenght

*** possibility montage on the pedestal or boom/column

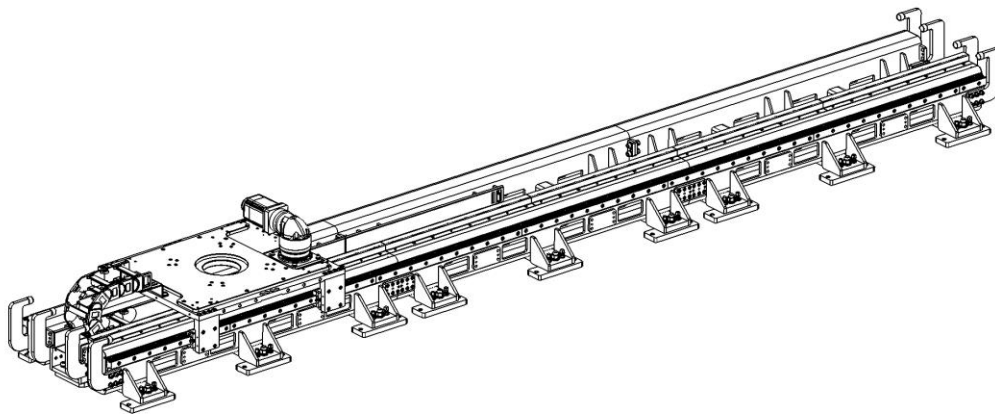

3. External dimensions

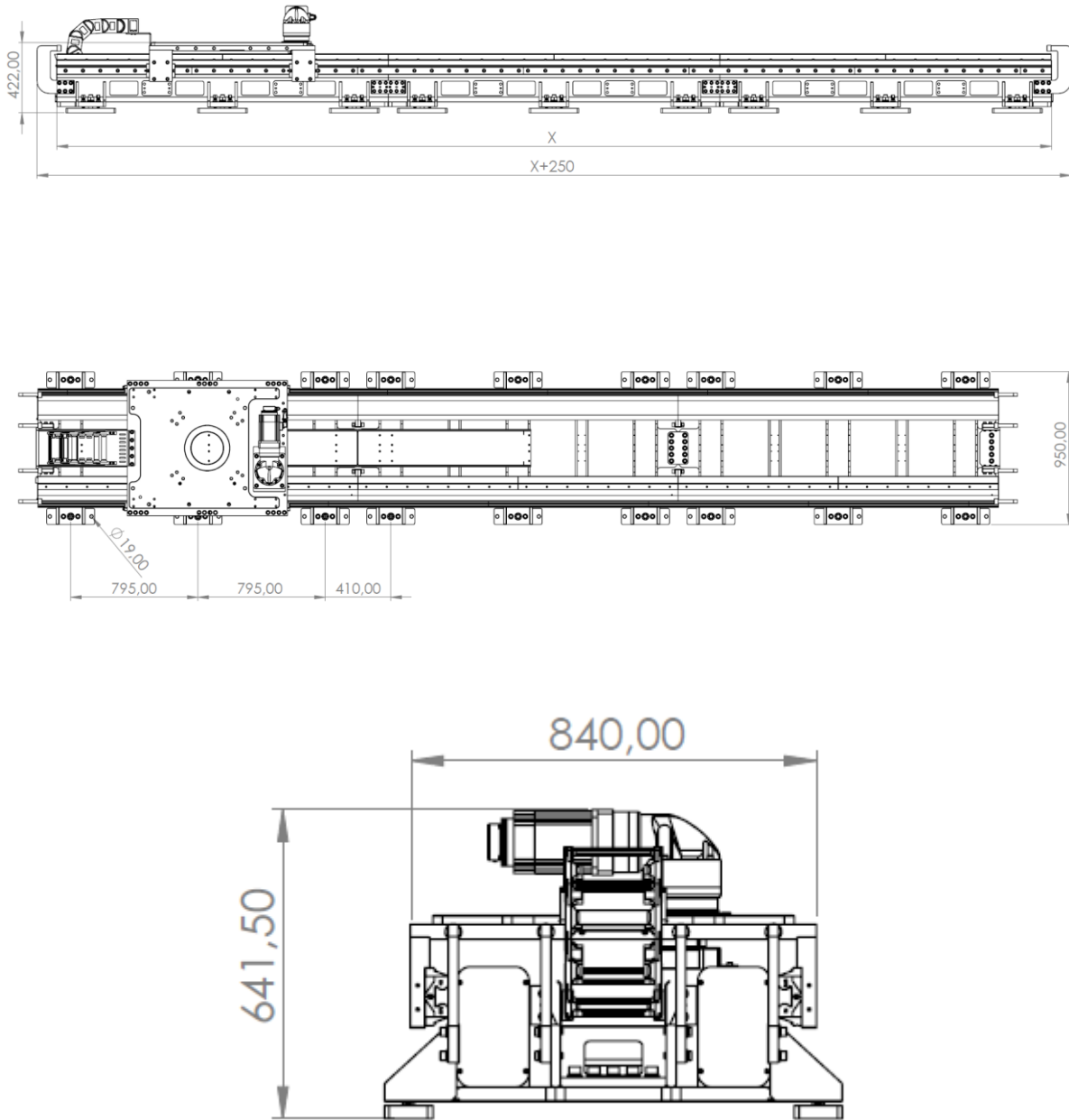
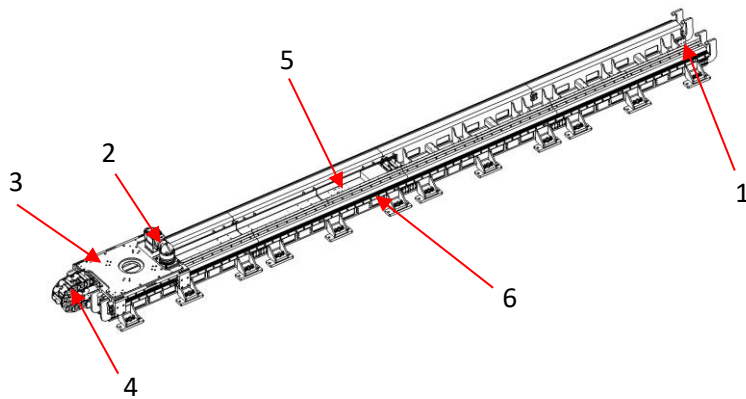

Fig. 1 Basic dimensions of the linear track with spacing of fixing holes, X – travel distance

4. Basic assemblies of the basic module

4.1. Mechanical system



1. Rating plate,
2. Servo Kawasaki 2kW,
3. Linear track's carriage TRK1000.
4. Linear guideway Icus
5. Toothed Bar
6. Linear Guideways

Fig. 2 Basic assemblies of the basic module

4.2. Electrical system

The power units consist of:

Axis 1 (Linear move) Servo-Motor Kawasaki 2.0kW and planetary gearbox.

The axes are controlled as external axes from the robot control system. It is not possible to move the carriage without connecting it to the KAWASAKI robot controller.

5. Assembly and start-up

5.1. Assembly

The TRK1000 is assembled, connected, and pre-commissioned by the personnel appropriately prepared for this task. These persons are assigned by the manufacturer. These persons have the knowledge and skills required to safely and correctly assemble the machine. Connection to the mains must be carried out in accordance with the Polish Standards. It is not allowed to carry out the assembly independently; this will result in loss of warranty. During the warranty period, the user may not interfere in the electronic or mechanical components except as set forth in this maintenance documentation. Failure to comply with the above will result in loss of warranty.

Linear track must be leveled and fixed to the ground using foundation bolts, M12 bolts with a strength class of at least 10.9 or chemical anchor bolting M12 x 150mm. The spacing of the mounting holes fixing the track to the slab is shown in Figure 1. In case of robot with load capacity below 20 kg should be anchored every other mounting hole in the robot base, for robots with a higher load capacity, this should be anchored through each mounting hole.

Concrete class at least c20 - Surface slope up to 5 degrees, Surface irregularities up to 5mm

Detailed installation instructions are described in the instructions „**K-positioner - TRK1000 Installation Manual**”

5.2. Getting ready for operation

After completing the installation work on the linear track:

- Perform all the tasks on connecting the robotic station,

The definition of the external axis is described in the documentation of the External Axis (90210-1292DEC_External_Axis_Addition_Manual_(EOx-Series)).

5.3. Emergency Stop connection

Safety of the linear axis is ensured by the robot safety circuits and the circuits must be prepared in accordance with Kawasaki technical documentation.

5.3.1. Cubic-S Option

The Cubic-S option can further control the status of the Kawasaki exterior axis. In order for Cubic-S to monitor the linear axis, a value other than "0" should be set in the axis cooperation settings (cooperation enabled, with one of the robot axes).

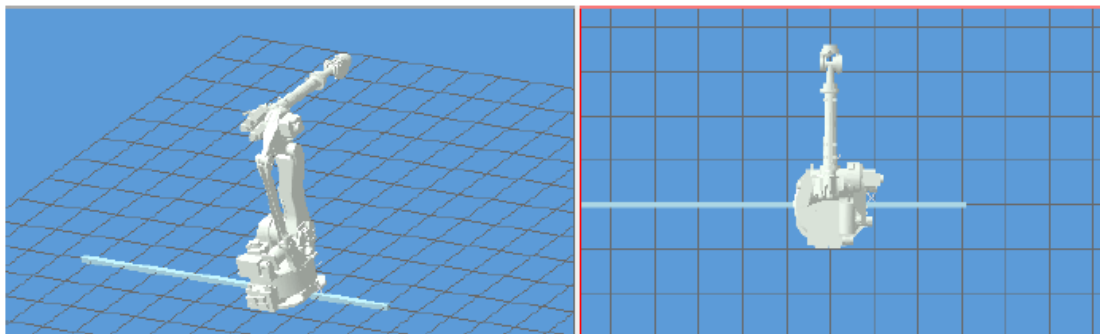

Fig. 3 Stop Monitoring Declaration for ancillary axis in the Cubic-S option

The definition of the dedicated input for monitoring the status of the ancillary axis in CUBIC-S is described in **CUBIC-S (90210-1272DEC_Cubic-S_Instruction Manual (E series))**.

5.4. Start-up

To start the linear track, connect it to the robot controller.

Activation of linear track is synonymous with the activation of the robotic station and follows the algorithm of the station's operation.

To move the JT7 axis, press the 7 "+" or "-" button on the TeachPendant with the motors off and DeadMan Switch on.

5.5. Working conditions and safe use.

The TRK1000 linear track is suitable for indoor use in the following environmental conditions:

- Air free from condensed steam, dust, corrosive or explosive gases,
- Permissible ambient temperature: +5°C ÷ +40°C.

When operating the linear track:

- Observe all the safety rules for safe work at a robotic station;
- Get acquainted with possible health or life hazards due to improper operation of the device;
- An employee handling the robotic station with the TRK1000 linear track must be familiar with the contents of this Operation and Maintenance Manual and the Operation and Maintenance Manual for the industrial robot;
- It is not permitted to carry out maintenance work during the operation of the station
- It is forbidden to leave tools on the housing and servo drives.

Detailed health and safety regulations should be developed by the user at the workplace. Observe general health and safety regulations for electrical and mechanical equipment when connecting, starting-up and operating the linear track.

It's not permitted for persons to be present in the operating area of the track during the work of the machine, as well as for unauthorized persons to carry out repairs and maintenance.

Secure the robot in the area of the linear track workstation with fences and light barriers in accordance with Polish safety standards.

5.6. Maintenance of the linear track

Maintenance procedures include measures aiming at reducing wear on parts and components of the mechanical system and ensuring correct linear track operation. Maintenance should be carried out by trained personnel. The service technician authorized to carry out repairs is the manufacturer or a person designated by the manufacturer. The warranty does not cover mechanical damage resulting from improper use of the station.

Before performing any maintenance work, make sure the equipment is disconnected from the mains

5.7. Maintenance schedule

Action	Period of time	
	Daily inspection	5000 hours
Physical damage	<input checked="" type="checkbox"/>	<input checked="" type="checkbox"/>
Gear backlash and abnormal sounds during operation	<input checked="" type="checkbox"/>	<input checked="" type="checkbox"/>
Check the linear track brakes		<input checked="" type="checkbox"/>
Toothed Bar Lubrication		<input checked="" type="checkbox"/>
Check the internal wires		<input checked="" type="checkbox"/>
Battery change		<input checked="" type="checkbox"/>
Linear Track Carriages Lubrication		<input checked="" type="checkbox"/>
Checking the tightening torque of the assembly screws *		<input checked="" type="checkbox"/>

* in case of parts replacing

6. Lay of user cables inside the structure

The linear track allows you to carry out the wires through the IGUS cable guides.

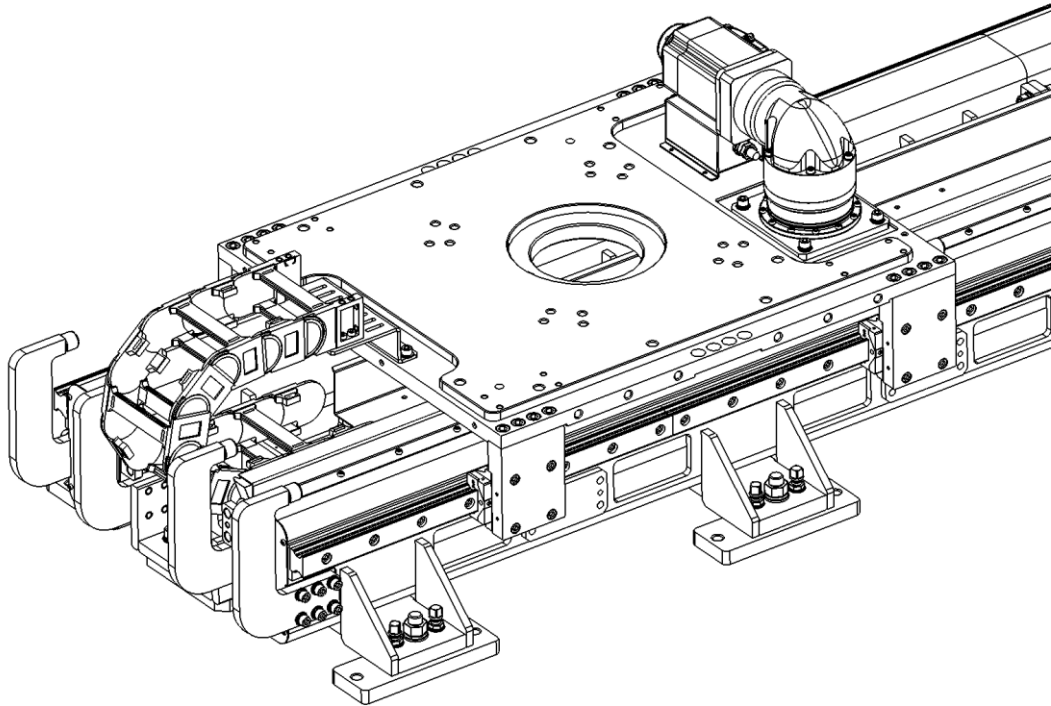

Fig. 4 Cable routing in IGUS energy chains

7. Storage and transport conditions

7.1. Storage

The TRK1000 linear track should be stored indoors, in rooms free from aggressive corrosive agents. Ambient temperature should range between $+5\text{ }^{\circ}\text{C}$ ÷ $+40\text{ }^{\circ}\text{C}$ and humidity should not exceed 80%. The track should also be protected against shocks and vibrations.

7.2. Transport

Transport of the TRK1000 linear track should be carried out by clean, dry and covered means of transport, protected against penetration of precipitation into the interior and against exceeding the temperatures of $+50\text{ }^{\circ}\text{C}$ and $-25\text{ }^{\circ}\text{C}$. At the same time the track must be protected against sliding.

8. Safety information and residual risk

The TRK1000 has been designed and built for precise positioning of objects attached to it in one axis, depending on the used version of the device. It is a prerequisite for the safe use of the device described above that the maximum permissible load shown in this manual is not exceeded.

8.1. Danger due to mechanical construction:

8.1.1. Crushing and cut-offs

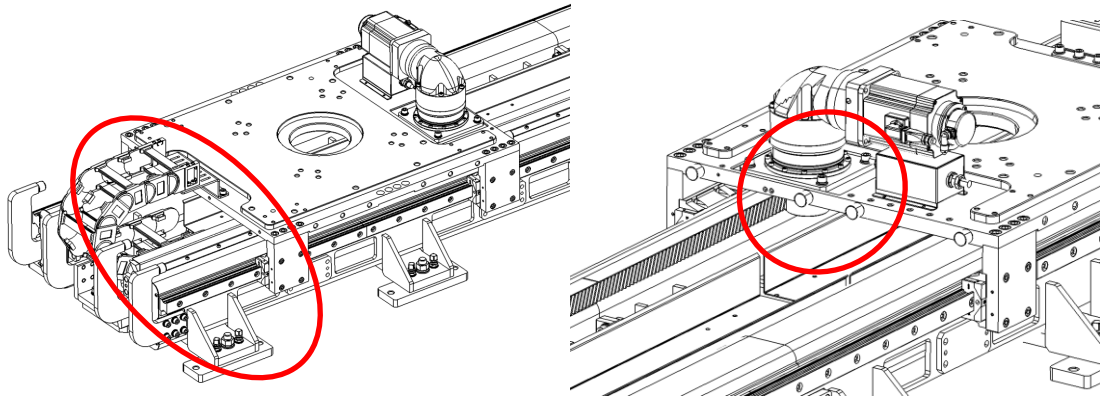

Fig. 5 Areas with the risk of crushing

There is a risk of crushing, cutting fingers or other parts of the body in the marked areas. Do not leave or put any tools or parts of the body or animals in these areas.

It is forbidden to stay in the work zone while the Linear Track is in operation.

8.2. Dangers due to the electrical system

After connecting the TRK1000 linear track to the mains, it is forbidden to connect and/or disconnect the wiring of the device; these actions may result in an electric shock.

8.3. Informations about noise emission

The level of the emitted acoustic pressure at the workstations, corrected by the A characteristics, does not exceed the value of 70 dB (A). Peak momentary acoustic pressure at work stations, adjusted by C, does not exceed 63 Pa (130 dB versus 20 μ Pa).

9. Notes

Appendix 1.

Parts of the linear track must be ordered from the ASTOR company. List of branches available at: <http://www.astor.com.pl/kontakt.html>. In order to improve order handling, please specify the positioner model and the part name along with the code.

Spare Parts List:

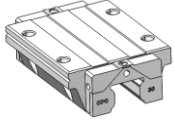
	Nazwa	Product code	Quantity [pcs.]
Servo-drive Kawasaki 2kW		50601-1460	1
Planetary gear		AD140-014-Po	1
Linear carriage		HCR45FL	4

10. Manufacturer's data



Astor Sp. z o.o.

Ul. Smoleńsk 29, 31-112 Kraków

Phone number: +48 (12) 428 63 00

Fax: +48 (12) 428 63 09

e-mail: info@astor.com.pl

NIP: 676 01 05

